

## Nu Mail Letterplate Security Shield

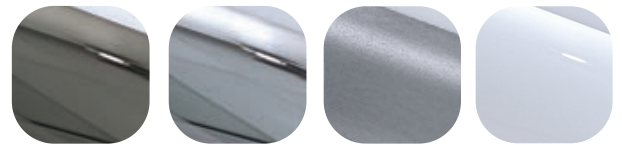

### Features

- Stylish letterplate shield design**  
 Designed to provide additional security to your door
- Specifically engineered to prevent access**  
 To the door handle or cylinder by means of an intruder reaching through the letterplate to gain access to the home
- Designed to maintain clear access**  
 Required for postal items while providing additional peace of mind to homeowners
- Fully colour matched metal shield suited to the Nu Mail letterplate**  
 Quality and durability you can see and feel
- TS008 accreditation**  
 Combination of the Nu Mail 76mm letterplate and security shield has been successfully tested to the latest TS008:2015 standards for doors
- Fully compliant to the latest PAS24 requirements and Document Q**  
 Security shield/ cowl sits flush against the Nu Mail letterplate on the door to provide an attract yet compliant solution to the latest changes to PAS24
- Secure Jack Nut or screw through fixing**  
 Fixings suitable for all applications
- Supplied with fixings for Jack Nut installation**  
 Everything needed for installation included



Hardex Bronze

Hardex Chrome

Hardex Graphite

White

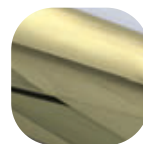

Hardex Gold

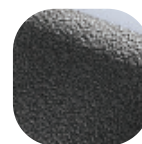

Antique Black



Black



When used with the Nu Mail letterplate



When used with the Nu Mail letterplate

## Nu Mail Letterplate Security Shield

### Corrosion resistance

Meets the requirements of BS EN 1670:2007 Grade 5 (480 hours)

### Performance

Independently tested to meet the requirements of TS008: 2015 (Inc. Corr, No 1) when used in conjunction with the Fab&Fix 3C 76mm Nu Mail Letterplate. Designed to meet the requirements of PAS 24 in a compliant door set.

### Fixings

Includes 4 x M5 x 65mm screws, 4 x Jack Nuts and 2 x cover caps.

### Material Specification

Frame:	High quality Zinc
Coatings:	Hardex Chrome, Hardex Bronze, Hardex Gold, Hardex Graphite, Antique Black, White and Black.

### Classification

The Nu Mail Security Shield (Cowl) has been certified to TS008:2015 and carries the following classification:

Category	1	2	3	4	5	6	7	8
Classification	B	1	2	N	3	N	0	0

### Packaging

#### Nu Mail Letterplate Security Shield

Individually boxed with fixings and care instructions.  
10 letterplate shields in an outer box.

### Maintenance

For continued protection of the quality finish and appearance, Fab&Fix advise routine cleaning of all our external hardware. Moving parts should also be lightly lubricated at least twice a year. This procedure is particularly essential if products are used within a 25-mile radius of coastal areas or close proximity to building sites or large industrial areas, where more frequent cleaning may be required to prevent the accumulation of corrosive contaminants.

Letterplate Shield

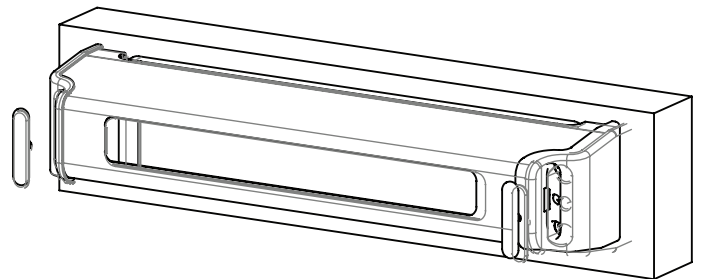
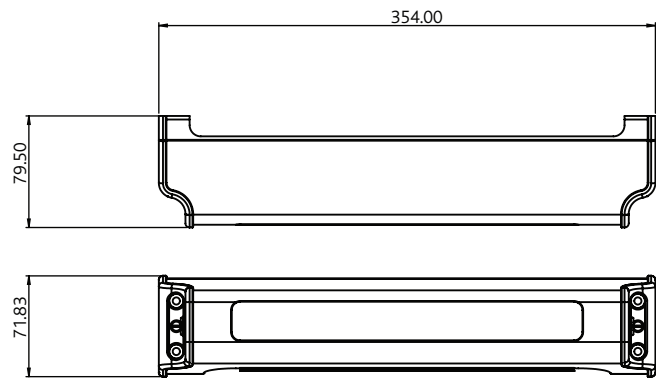
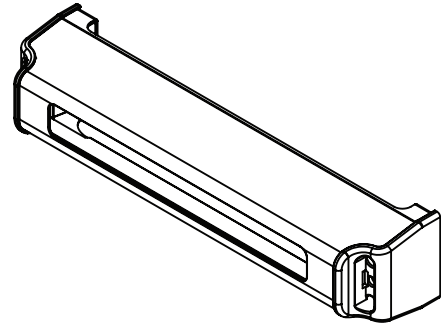

Routing Detail

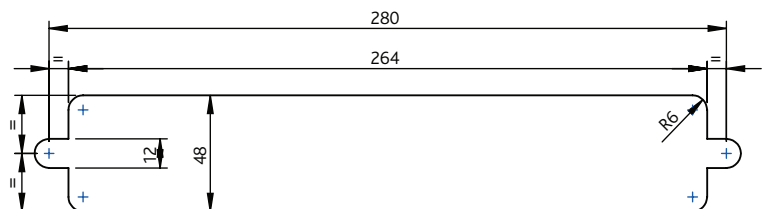

All dimensions are in mm.

ERA reserves the right to change specification without notice.

It is the responsibility of the door manufacturer to ensure that the finished product meets any required safety and performance specification.